

Pacific 40° Fixed Beam



A base down axial ellipsoidal delivering a “cool” beam of 40°. The beam is a crisp “white” light with little or no distortion, ideal for gobo projection and precise beam shaping.

An energy efficient fixture with Active Heat Management system delivers longer life for filters and shutters while providing lower energy consumption.

Features

Cool ‘white’ light. Over 80% of the heat is removed from the light beam by the cold mirror and dissipated through the heat-sink.

Base down lamp mounted axially in the reflector to maximize light collection.

Accurate and easy to use lamp peak/ flat adjustment.

Two gobo/ iris mounting positions.

Height adjustable yoke.

Permanently attached safety cable ensures that this important safety requirement is always on hand.

Integral micro-switch provides automatic disconnection of power to the fixture when opening to relamp, preventing a student or technician inserting a lamp into an electrically live fixture.

Three year warranty.

Approvals

ETL / cETL listed to UL 1573.

Lamps: 115V

GLC 575W 15,500 lumens	300hrs average life
GLA 575W 13,000 lumens	1500hrs average life
GLD 750W 18,600 lumens	400hrs average life
Philips 120V 750W 20,500 lumens	Type code 6981P 300hrs average life
GAC 1000W BP 27,000 lumens	250hrs average life

Ordering information

PAC1-575/750-40	Pacific 40 Fixed Beam, 575W/750W
PAC1-1000-40	Pacific 40 Fixed Beam, 1000W
19PACGHA	Steel gobo holder – A size
19PACGHAG	Glass gobo holder – A size
19PACGHPLPH	Printed transparency holder – 575W only
20IRIS	Iris
19PACFBDONUT	Donut
19PACCF	Spare color frame
19PACSMFB	Lens safety mesh
USCLAMP	Spare US theatrical C-clamp

For connector options please specify the following suffixes when ordering:

- GR NEMA 5-15P Grounded Edison
- GP 20A Stage Pin Plug
- GTL NEMA L5-20P Twist-Lock

SPECIFICATION SUBMITTAL

CONSULTANT: <input type="text"/>	PROJECT NAME: <input type="text"/>	MODEL NUMBER QUANTITY: <input type="text"/> <input type="text"/> <input type="text"/> <input type="text"/>
DATE: <input type="text"/>	PROJECT NUMBER: <input type="text"/>	APPROVED BY: <input type="text"/>

Photometric data

Tests conducted using standard 115V production lamps manufactured by Philips.

Beam angle	40 °, ft	Beam Diameter in ft									
		0	9.5	19.3	28.8	38.2	48.0	57.5	67.0	76.4	
Throw Distance in ft		0	13	26.5	39.5	52.5	66	79	92	105	
Lamp		Light Output in Footcandles									
115V 750W	40° Peak	465	112	50	-	-	-	-	-	-	
	Flat	251	60	-	-	-	-	-	-	-	
115V GLC 575W	40° Peak	390	94	42	-	-	-	-	-	-	
	Flat	190	46	-	-	-	-	-	-	-	
115V BP 1000W	40° Peak	465	112	50	-	-	-	-	-	-	
	Flat	260	63	-	-	-	-	-	-	-	

To calculate the light output data for the long life GLA 575W lamp please multiply the above GLC 575W figures by x0.86.

For Lux please multiply Fc by 10.7

Physical data

Weight: 18lbs 8oz

Carton size: 25 1/2" x 15 3/4" x 10 5/8"

Color frame size: 6 1/4" x 6 1/4"

Gobo size: A Size, 3" diameter image

Gobo holder width: 4 3/4"

AC supply cable: 36"

Included: 1x color frame, 1x safety cable, 1x C-clamp, 1x heat sink guard and instruction sheet.

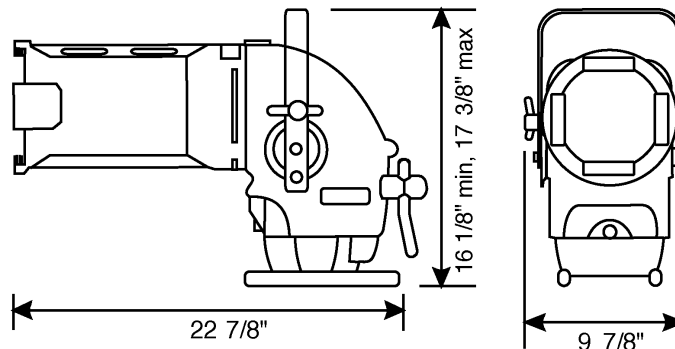

North America

10911 Petal Street
Dallas, Texas 75238
Tel: +1 214 647 7880
Fax: +1 214 647 8030

267 5th Ave, 4th Floor
New York, NY 10016
Tel: +1 212 213 8219
Fax: +1 212 532 2593

New Zealand

19-21 Kawana Street
Northcote, Auckland 0627
Tel: +64 9 481 0100
Fax: +64 9 481 0101

Hong Kong

Room 6-10
20/F Delta House
3 On Yiu Street
Shatin, N.T.
Tel: +852 2757 3033
Fax: +852 2757 1767

European Service & Distribution Centre

Marssteden 152
Enschede 7547 TD
the Netherlands
Tel: +31 53 450 0424
Fax: +31 53 450 0425

063010NA

© Philips Group 2010

All rights reserved.

The Company reserves the right to make any variation in design or construction to the equipment described.
E&OE

PHILIPS
Selecon